

# C-LOK

C-LOK Instrument Valve Co.,Ltd.

Ball Valves



# C-LOK

## Contents

**01** One-piece Instrument Ball Valves  
B1 Series



**06** Hex Bar Stock Ball Valves  
B2 Series



**10** Trunion Ball Valves  
B3 and B3H Series



**17** Bar Stock Ball Valves  
B4 Series



**23** 3-piece Ball Valves  
B5 Series High Pressure Application



# One-piece Instrument Ball Valves

## Features

- Working pressure up to 3000 psig (207 bar)
- Working temperature from -65°F to 300°F (-54°C to 148°C)
- 2-way, 3-way models for on-off and switching service available
- One piece body and one piece ball stem eliminates multiple seal points
- Top entry design allows in-line inspection and repair after system depressurizing, simplifies maintenance
- Live-loading with packing springs compensates for thermal effects and wear
- Pneumatic and electric actuation available
- Panel mountable
- 100% factory tested



## Technical Data

Temperature		Working pressure, psig (bar)
°F	°C	
-65~50	-54~10	3000(207)
50~150	10~65	3000(207)
200	93	2800(193)
250	121	2650(182)
300	148	2500(172)

# One-piece Instrument Ball Valves

## Materials of Construction

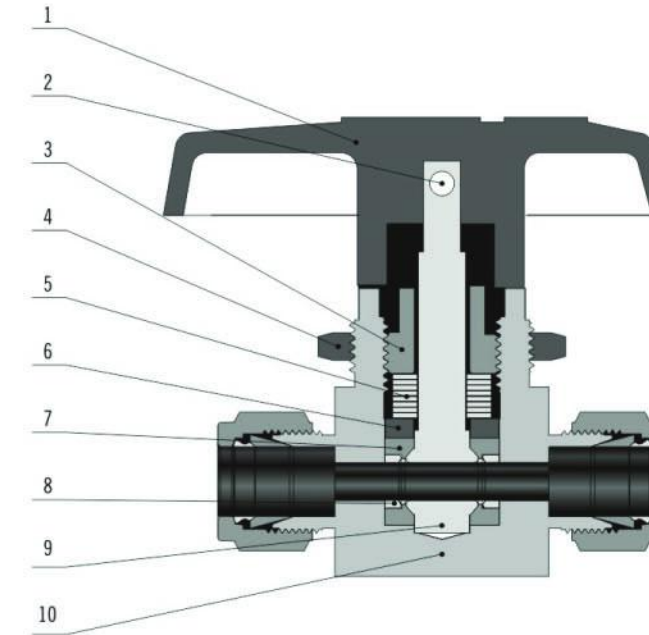

Item	Component	Valve Body Materials		
		Stainless Steel	Brass	Alloy 400
		Material Grade/ASTM Specification		
1	Handle	Aluminum alloy		
2	Set screw	302 SS		
3	Packing screw	316 SS/A176	Brass CDA 360/B16	Alloy R-405/B164
4	Panel nut	S17400S	Brass CDA 360/B16	S17400S
5	Packing springs	316 SS/A240		
6	Gland	316 SS/A276		
7	Packing seat	PTFE/Reinforced PTFE/UHMWPE		
8	Support rings	Fluorocarbon coated 316 SS/A276		Fluorocarbon coated alloy 400
9	Ball stem	316 SS/A276 and A479		Alloy R-405/B164
10	Body	316 SS/A182	Brass CDA 360/B283	Alloy 400/B564
	Lubricant	Hydrocarbon-based and silicone-based		

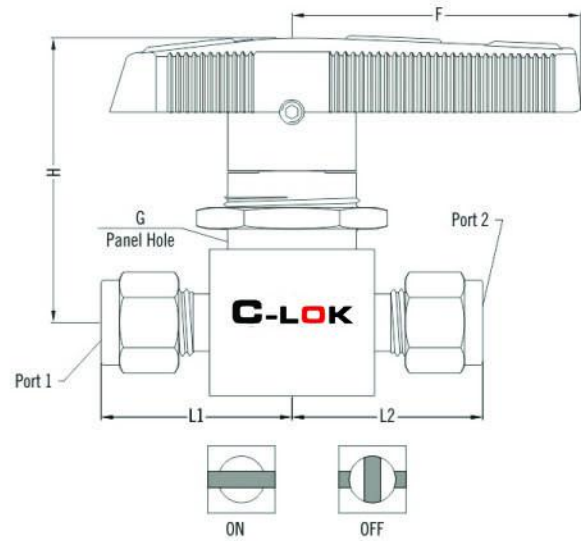

B1 (straight pattern)

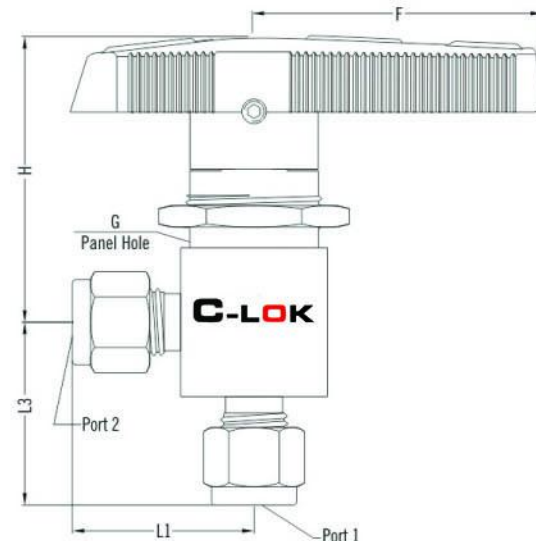

B1-A (angle pattern)

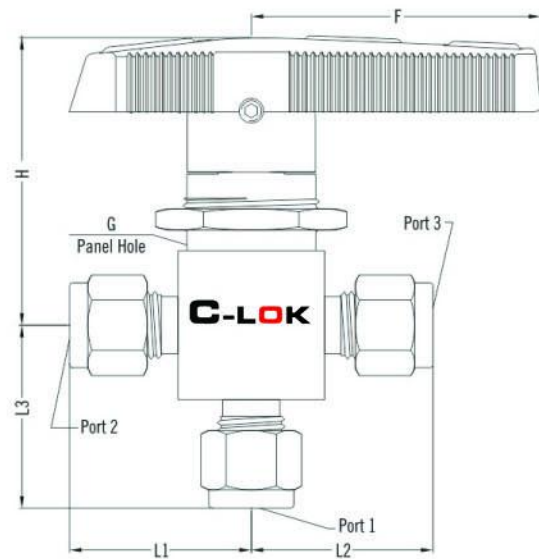

B1-X (3-way pattern)

Table of Dimensions

Basic Model Number	End Connection		Orifice in. (mm)	Cv	L1	L2	L3	H	F	G
	Port 1	Port 2/3			in. (mm)					
-B1-S1-1	1/16" OD	1/16" OD	0.052 (1.32)	0.10	0.84 (21.3)	0.84 (21.3)	0.84 (21.3)	1.36 (34.5)	1.12 (28.4)	0.59 (15.1)
-B1-S2-2	1/8" OD	1/8" OD	0.093 (2.36)	0.20	1.01 (25.7)	1.01 (25.7)	0.97 (24.6)	1.36 (34.5)	1.12 (28.4)	0.59 (15.1)
-B1-SM3-2	3mm	3mm								
-B1-F2-3	1/8 Female NPT	1/8 Female NPT			0.81 (20.6)	0.81 (20.6)	0.81 (20.6)			
-B1-S4-3	1/4" OD	1/4" OD	0.125 (3.18)	0.60	1.10 (27.9)	1.10 (27.9)	1.07 (27.2)	1.36 (34.5)	1.12 (28.4)	0.59 (15.1)
-B1-SM6-3	6mm	6mm								
-B1-F2-5	1/8 Female NPT	1/8 Female NPT			1.00 (25.4)	1.00 (25.4)	1.00 (25.4)			
-B1-F4-5	1/4 Female NPT	1/4 Female NPT			1.03 (26.2)	1.03 (26.2)	1.03 (26.2)			
-B1-FR4-5	1/4 Female BSPT	1/4 Female BSPT								
-B1-M4-5	1/4 Male NPT	1/4 Male NPT	0.187 (4.75)	1.5	1.00 (25.4)	1.00 (25.4)	1.03 (26.2)			
-B1-M4-S4-5	1/4 Male NPT	1/4" OD			1.12 (28.4)	1.00 (25.4)	1.03 (26.2)	1.47 (37.3)	1.53 (38.9)	0.78 (19.8)
-B1-S4-5	1/4" OD	1/4" OD			1.20 (30.5)	1.20 (30.5)	1.17 (29.7)			
-B1-S6-5	3/8" OD	3/8" OD			1.29 (32.8)	1.29 (32.8)	1.29 (32.8)			
-B1-SM6-5	6mm	6mm			1.20 (30.5)	1.20 (30.5)	1.17 (29.7)			
-B1-SM8-5	8mm	8mm			1.23 (31.2)	1.23 (31.2)	1.20 (30.5)			
-B1-F4-7	1/4 Female NPT	1/4 Female NPT								
-B1-F6-7	3/8 Female NPT	3/8 Female NPT	0.281 (7.14)	6.0	1.25 (31.8)	1.25 (31.8)	1.25 (31.8)			
-B1-FR6-7	3/8 Female BSPT	3/8 Female BSPT						2.07 (52.6)	2.00 (50.8)	1.13 (28.6)
-B1-S6-7	3/8" OD	3/8" OD			1.52 (38.6)	1.52 (38.6)	1.43 (36.3)			
-B1-SM10-7	10mm	10mm								
-B1-SM12-7	12mm	12mm								
-B1-SM14-7	14mm	14mm			1.56 (39.7)	1.56 (39.7)	1.47 (37.4)			
-B1-F8-10	1/2 Female NPT	1/2 Female NPT								
-B1-FR8-10	1/2 Female BSPT	1/2 Female BSPT			1.56 (39.7)	1.56 (39.7)	1.56 (39.7)			
-B1-S8-10	1/2" OD	1/2" OD	0.406 (10.3)	12				2.43 (61.7)	3.00 (76.2)	1.50 (38.1)
-B1-S12-10	3/4" OD	3/4" OD			1.96 (49.8)	1.96 (49.8)	1.74 (44.2)			
-B1-SM12-10	12mm	12mm								
-B1-SM14-10	14mm	14mm								
-B1-SM16-10	16mm	14mm								

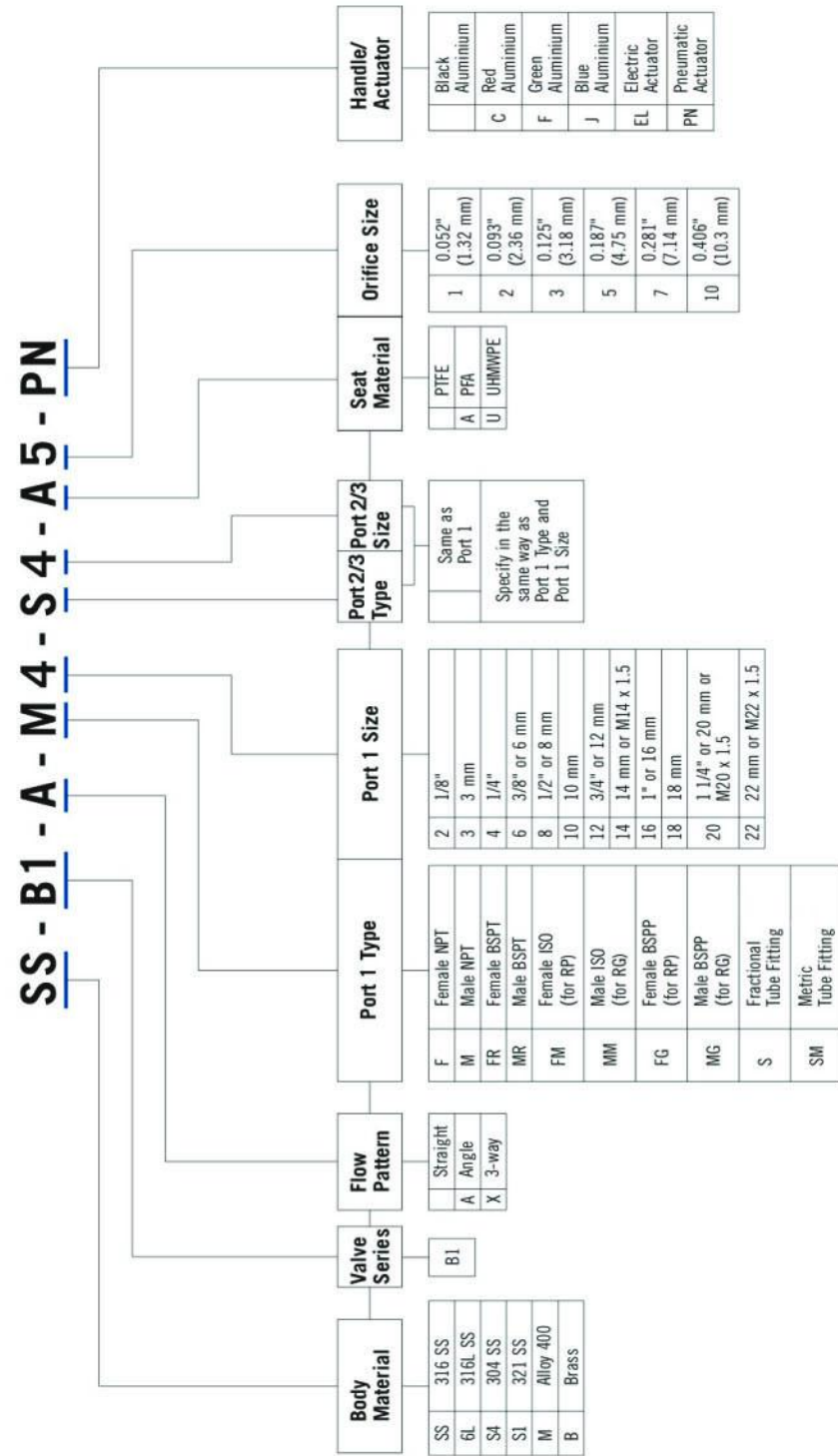

**Features**

- Working pressure up to 2000 psig (138 bar)
- Working temperature from -65°F to 450°F (-54°C to 232°C)
- Size from 1/8" to 1" or 6 mm to 25 mm
- Compact design with one piece hexagon body
- Low torque for easy operation
- Free floating ball design provides seat wear compensation
- 100% factory tested



**Technical Data**

Temperature		Working pressure, psig (bar)
°F	°C	
-65~100	-54~37	2000(138)
150	65	1820(125)
200	93	1650(113)
250	121	1480(101)
300	148	1310(90)
350	176	1140(79)
400	204	970(67)
450	232	800(55)

## Materials of Construction

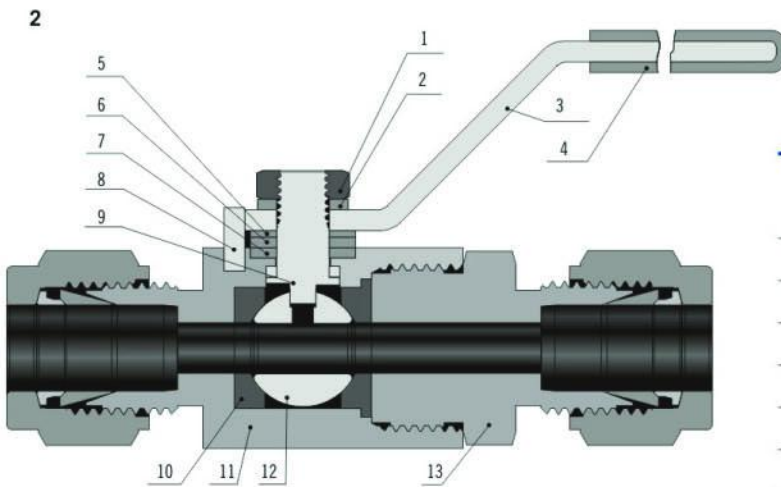

Item	Component	Body Materials	
		316 SS	Brass
1	Stem nut	316 SS	
2	Spring washer	Spring steel	
3	Handle	316 SS	
4	Handle sleeve	Vinyl	
5	Washer	304 SS	
6	Gland	316 SS/A276	
7	Packing	PTFE (TFM1600)	
8	Stop pin	316 SS/A276	
9	Stem	316 SS/A276	
10	Seat	Reinforced PTFE	
11	Body	316 SS/A276	Brass/B453
12	Ball	316 SS/A479	
13	End connector	316 SS/A276	Brass/B453

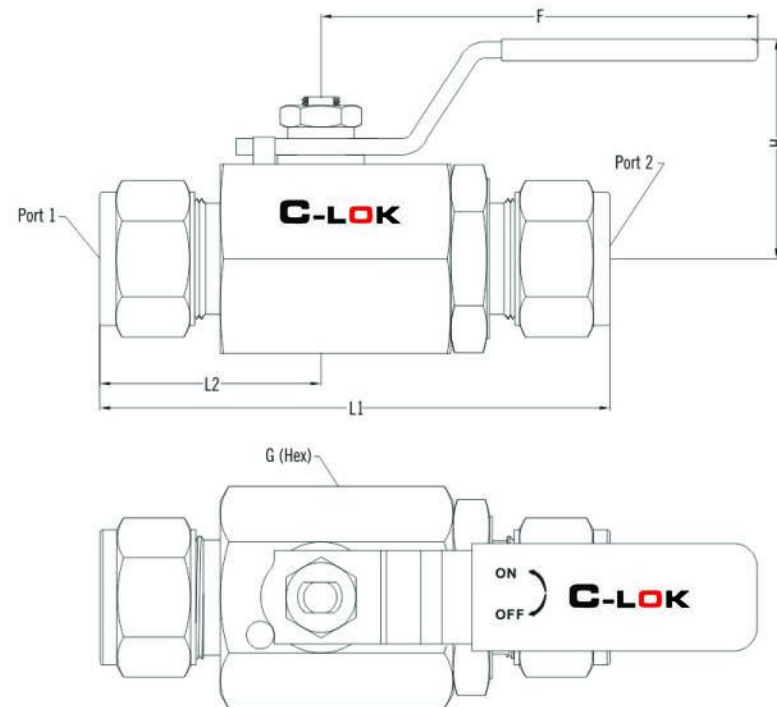

## Table of Dimensions

Basic Model Number	End Connection		Orifice in. (mm)	Cv	L1	L2	H in. (mm)	F	G
	Port 1	Port 2/3							
-B2-F2-5	1/8 Female NPT	1/8 Female NPT	0.197 (5.0)	1.25	1.85 (47)	0.77 (19.6)	1.18 (30.0)	2.36 (60.0)	3/4 (19.05)
-B2-F4-5	1/4 Female NPT	1/4 Female NPT							
-B2-FR4-5	1/4 Female BSPT	1/4 Female BSPT							
-B2-S4-5	1/4" OD	1/4" OD							
-B2-SM6-5	6mm	6mm							
-B2-F6-7	3/8 Female NPT	3/8 Female NPT	0.28 (7.1)	2.5	2.03 (51.6)	0.81 (20.6)	1.18 (30.0)	2.36 (60.0)	7/8 (22.23)
-B2-FR6-7	3/8 Female BSPT	3/8 Female BSPT							
-B2-S6-7	3/8" OD	3/8" OD							
-B2-SM8-7	8mm	8mm							
-B2-SM10-7	10mm	10mm							
-B2-F8-9	1/2 Female NPT	1/2 Female NPT	0.35 (9.0)	9.25	20.3 (51.6)	0.85 (21.6)	1.54 (39.0)	3.15 (80.0)	15/16 (24.0)
-B2-FR8-9	1/2 Female BSPT	1/2 Female BSPT							
-B2-S8-9	1/2" OD	1/2" OD							
-B2-SM12-9	12mm	12mm							
-B2-F12-13	3/4 Female NPT	3/4 Female NPT							
-B2-FR12-13	3/4 Female BSPT	3/4 Female BSPT							
-B2-S10-13	5/8" OD	5/8" OD							
-B2-S12-13	3/4" OD	3/4" OD							
-B2-SM14-13	14mm	14mm							
-B2-SM16-13	16mm	16mm							
-B2-F16-16	1 Female NPT	1 Female NPT	0.63 (16.0)	17.35	3.01 (76.5)	1.49 (37.9)	1.77 (45.0)	3.94 (100.0)	1 5/8 (41.27)
-B2-FR16-16	1 Female BSPT	1 Female BSPT							
-B2-S16-16	1" OD	1" OD							
-B2-SM16-16	16mm	16mm							
-B2-SM25-16	25mm	25mm							

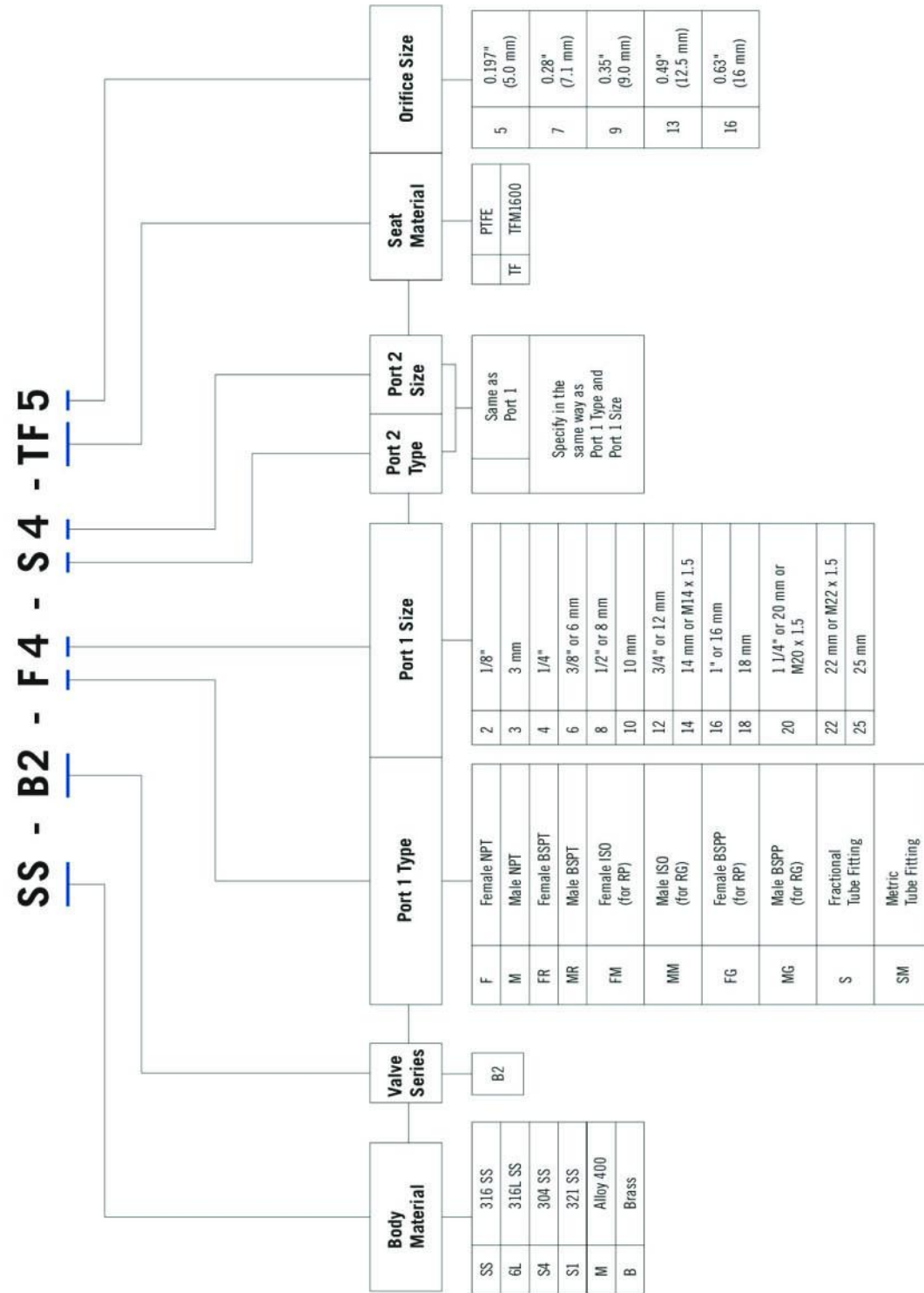

## Features

- Maximum working pressure: 10000 psig (690 bar)
- Working temperature: 0°F to 450°F (-17°C to 232 °C)
- Fixed ball with double sealing
- Automatic compensation of seat sealing
- Low operating torque
- Blowout proof stem
- Handle as indicator of flow direction
- Positive handle stop
- Pneumatic or electric actuator available
- Panel mountable
- Options for handle color
- Leak-tight performance testing with nitrogen for every valve at the maximum working pressure, but not higher than 6000 psig



## Pressure vs. Temperature

B3 Series

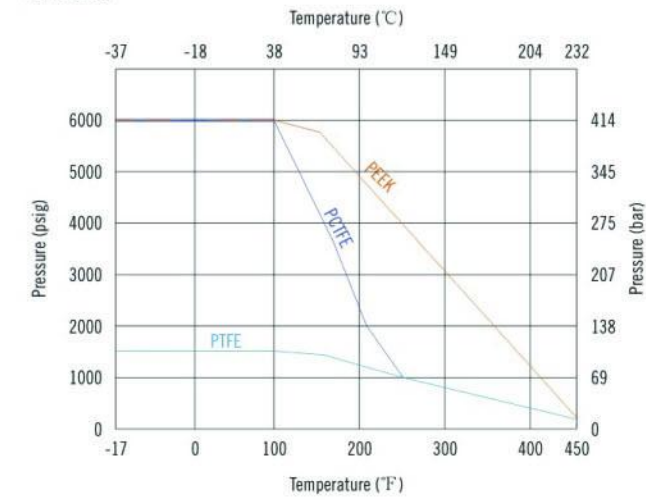

B3H Series

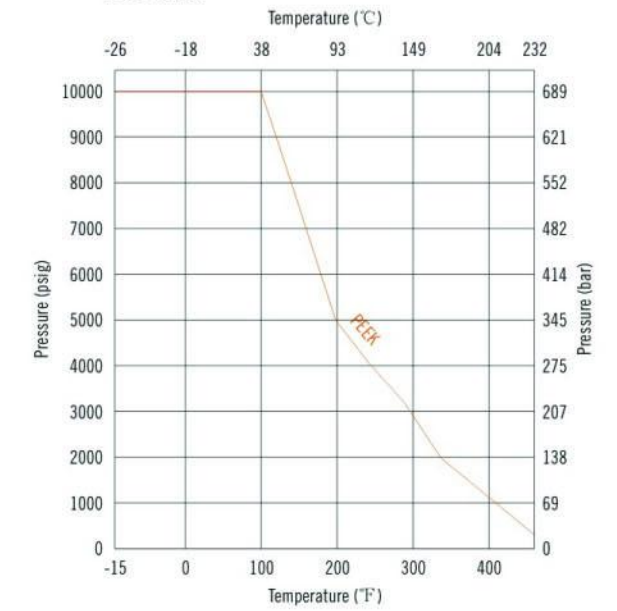

1. Graphs are for 2-way valves only
2. Maximum working pressure for 3-way valves:  
6000 psig: connection 1 as inlet, connection 2 and connection 3 as outlet  
3000 psig: connection 2 and connection 3 as inlet, connection 1 as outlet

# Trunnion Ball Valves

## Flow Data at 70°F (20°C)

**B3 Series 2-way**  
0.187" (4.75 mm) orifice, 1.2 Cv

Inlet Pressure psig (bar)	Pressure Drop ( $\Delta p$ ) psig (bar)	Air Flow std ft <sup>3</sup> /min (std L/min)	Water Flow U.S. gal/min (L/min)
1000 (69)	10 (0.69)	14 (334)	3.5 (13)
3000 (207)	50 (3.45)	30 (834)	7.5 (28)
6000 (414)	100 (6.89)	60 (1670)	11.0 (41)

**B3 Series 3-way**  
0.187" (4.75 mm) orifice, 0.75 Cv

Inlet Pressure psig (bar)	Pressure Drop ( $\Delta p$ ) psig (bar)	Air Flow std ft <sup>3</sup> /min (std L/min)	Water Flow U.S. gal/min (L/min)
1000 (69)	10 (0.69)	10 (275)	3.0 (11)
3000 (207)	50 (3.45)	23 (630)	7.0 (26)
6000 (414)	100 (6.89)	42 (1150)	9.5 (35)

**B3H Series 2-way**  
0.187" (4.75 mm) orifice, 1.2 Cv

Inlet Pressure psig (bar)	Pressure Drop ( $\Delta p$ ) psig (bar)	Air Flow std ft <sup>3</sup> /min (std L/min)	Water Flow U.S. gal/min (L/min)
1000 (69)	150 (10.3)	90 (2550)	15 (56)
6000 (414)	600 (41.4)	345 (9660)	30 (111)
10000 (689)	1000 (68.9)	560 (15680)	40 (148)

**B3H Series 3-way**  
0.187" (4.75 mm) orifice, 0.75 Cv

Inlet Pressure psig (bar)	Pressure Drop ( $\Delta p$ ) psig (bar)	Air Flow std ft <sup>3</sup> /min (std L/min)	Water Flow U.S. gal/min (L/min)
1000 (69)	150 (10.3)	55 (1540)	10 (37.0)
6000 (414)	600 (41.4)	200 (5600)	20 (74.0)
10000 (689)	1000 (68.9)	330 (9240)	25 (92.5)

# Trunnion Ball Valves

## Standard Materials of Construction

**B3 Series**

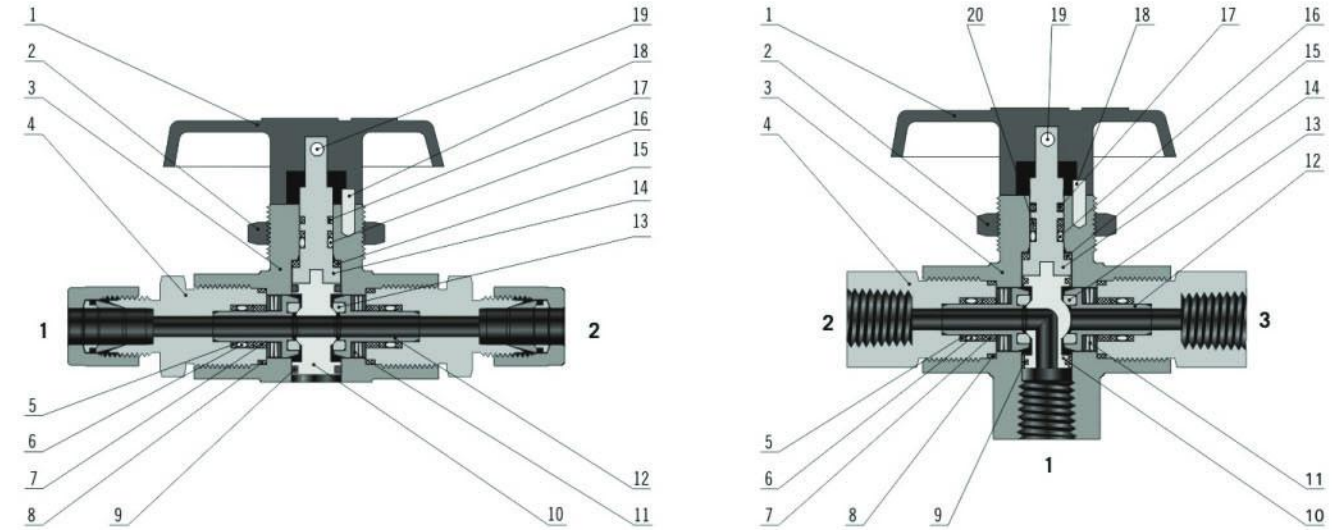

Item	Component	Valve Body Material			
		316 Stainless Steel		Alloy 400	
		2-way	3-way	2-way	3-way
Material Grade/ASTM Specification					
1	Handle	Nylon or aluminium			
2	Panel Nut	316 SS/B783			
3	Body	316 SS/A479		Alloy 400/B164	
4	End Connector	316 SS/A479		Alloy R-405/B164	
5	Seat Retainer Guide	Reinforced PTFE			
6	Seat Retainer O-ring	Fluorocarbon FKM			
7	Seat Carrier Guide	316 SS/A276		Alloy R-405/B164	
8	End Connector Seal	PTFE/D1710			
9	Trunnion Bearing	Fluorocarbon FKM	PEEK	Fluorocarbon FKM	PEEK
10	Ball	316 SS/A276	S21800/A276	Alloy R-405/B164	
11	Seat Spring	Alloy X-750/AMS 5542			
12	Seat Retainer	316 SS/A276		Alloy R-405/B164	
13	Seat	PTFE or PEEK or PCTFE			
14	Stem	316 SS/A276		Alloy R-405/B164	
15	Stem Washer	Reinforced PTFE	PEEK	Reinforced PTFE	PEEK
16	Stem O-ring	—	Fluorocarbon FKM	—	Fluorocarbon FKM
17	Primary Stem Backup Ring	PTFE/D1710			
18	Pin	Stainless Steel			
19	Set Screw	S17400 SS			
20	Secondary Stem Backup Ring	—	PEEK	—	PEEK
Lubricants		Molybdenum and Tungsten disulfide and Fluorinated-based			

1. Ball trunnions are PTFE coated in B3 series 2-way valve.  
2. Other materials are available upon request, refer to the ordering information.



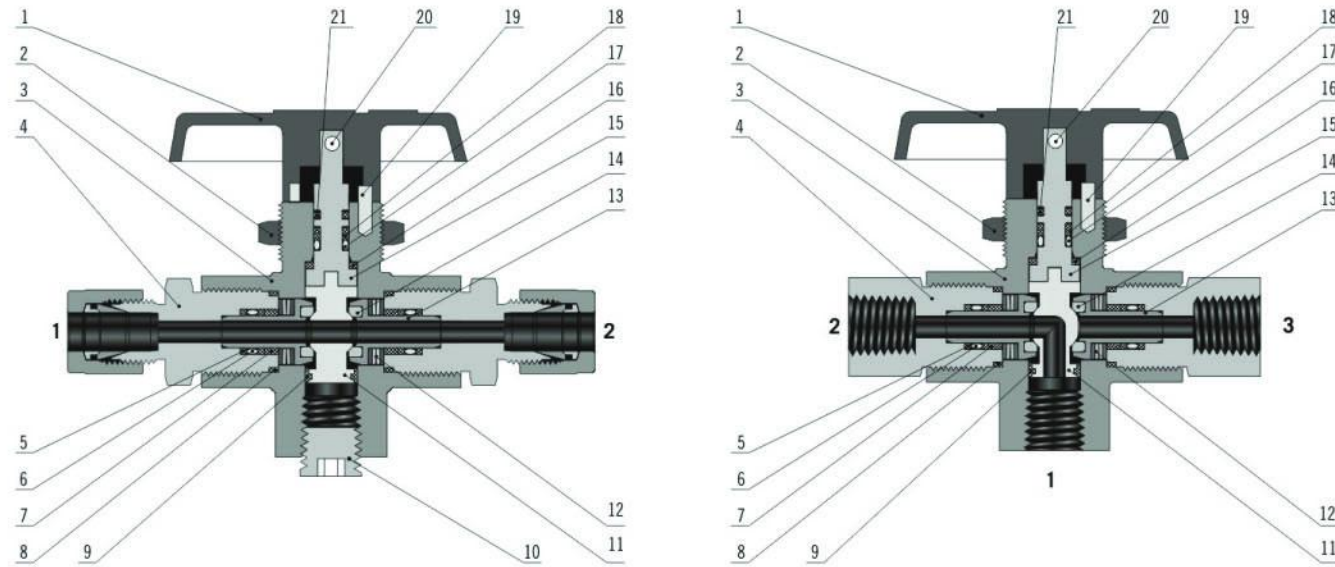

Item	Component	Material Grade/ASTM Specification	
		2-way	3-way
1	Handle	Nylon or aluminium	
2	Panel Nut	316 SS/B783	
3	Body	316 SS/A479	
4	End Connector	316 SS/A479	
5	Seat Retainer Guide	Reinforced PTFE	
6	Seat Retainer O-ring	Fluorocarbon FKM	
7	Seat Carrier Guide	316 SS/A276	
8	End Connector Seal	PTFE/D1710	
9	Trunnion Bearing	Fluorocarbon FKM	
10	Plug	316 SS/A276	
11	Ball	S21800/A276	
12	Seat Spring	Alloy X-750/AMS 5542	
13	Seat Retainer	316 SS/A276	
14	Seat	PEEK	
15	Stem	316 SS/A276	
16	Stem Washer	PEEK	
17	Stem O-ring	Fluorocarbon FKM	
18	Stem Back-up Ring	PTFE/D1710	
19	Pin	304 SS	
20	Set Screw	S17400/A564	
21	Stem Backup Ring	PEEK	
	Lubricants	Molybdenum and Tungsten disulfide and Fluorinated-based	

1. Ball trunnions are Xylan® coated in B3H series 2-way valve.  
 2. Other materials are available upon request, refer to the ordering information.

Dimensions in inches (millimeters), are for reference only and are subject to change.

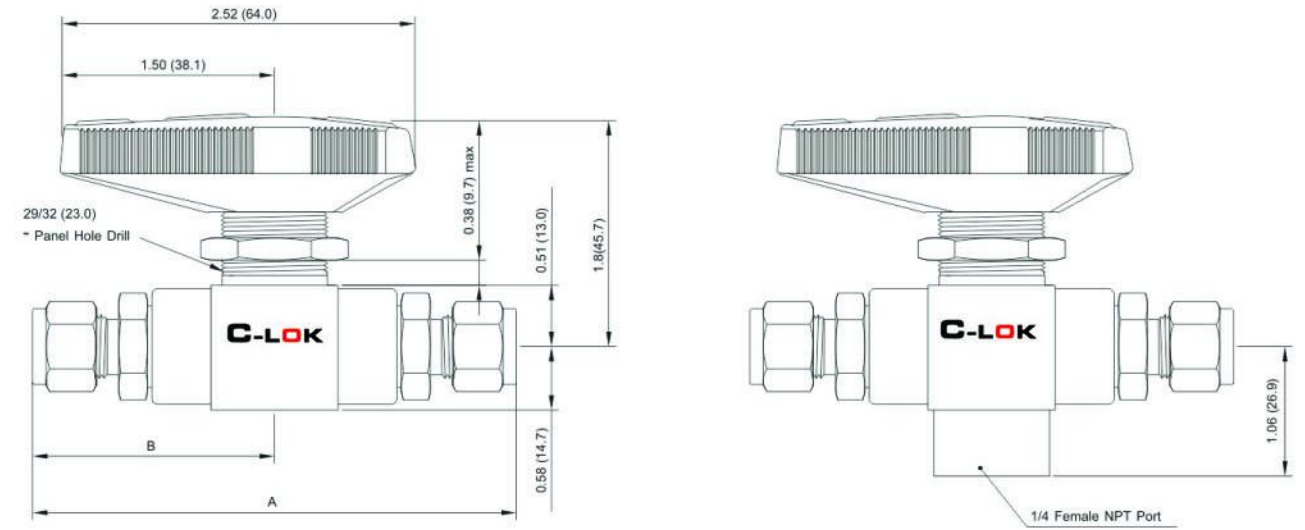

2-way Valve

Basic Ordering Number		Connection Size		Cv	Dimension, in. (mm)	
B3 Series	B3H Series	Connection 1	Connection 2		A	B
-B3-F2	-B3H-F2	1/8 Female NPT	1/8 Female NPT	1.2	2.94 (74.7)	1.47 (37.3)
-B3-F4	-B3H-F4	1/4 Female NPT	1/4 Female NPT		3.93 (99.8)	1.97 (50.0)
-B3-F8	-B3H-F8	1/2 Female NPT	1/2 Female NPT		4.25 (108.0)	2.13 (54.1)
-B3-S4	-B3H-S4	1/4" OD	1/4" OD		4.14 (105.2)	2.07 (52.6)
-B3-S6	-B3H-S6	3/8" OD	3/8" OD		4.39 (111.5)	2.19 (55.6)
-B3-S8	-B3H-S8	1/2" OD	1/2" OD		4.60 (116.8)	2.30 (58.4)
-B3-SM6	-B3H-SM6	6 mm	6 mm		4.14 (105.2)	2.07 (52.6)
-B3-SM8	-B3H-SM8	8 mm	8 mm		4.15 (105.4)	2.07 (52.6)
-B3-SM10	-B3H-SM10	10 mm	10 mm		4.41 (112.0)	2.20 (55.9)
-B3-SM12	-B3H-SM12	12 mm	12 mm		4.60 (116.8)	2.30 (58.4)

3-way Valve

Basic Ordering Number		Connection Size			Cv	Dimension, in. (mm)	
B3 Series	B3H Series	Connection 1	Connection 2	Connection 3		A	B
-B3-F2-3	-B3H-F2-3	1/4 Female NPT	1/8 Female NPT	1/8 Female NPT	0.75	2.94 (74.7)	1.47 (37.3)
-B3-F4-3	-B3H-F4-3		1/4 Female NPT	1/4 Female NPT		3.93 (99.8)	1.97 (50.0)
-B3-S4-3	-B3H-S4-3		1/4" OD	1/4" OD		4.14 (105.2)	2.07 (52.6)
-B3-S6-3	-B3H-S6-3		3/8" OD	3/8" OD		4.39 (111.5)	2.19 (55.6)
-B3-S8-3	-B3H-S8-3		1/2" OD	1/2" OD		4.60 (116.8)	2.30 (58.4)
-B3-SM6-3	-B3H-SM6-3		6 mm	6 mm		4.14 (105.2)	2.07 (52.6)
-B3-SM8-3	-B3H-SM8-3		8 mm	8 mm		4.15 (105.4)	2.07 (52.6)
-B3-SM10-3	-B3H-SM10-3		10 mm	10 mm		4.41 (112.0)	2.20 (55.9)
-B3-SM12-3	-B3H-SM12-3		12 mm	12 mm		4.60 (116.8)	2.30 (58.4)

## Service Option

### Low-temperature Service

Trunnion ball valves for low-temperature service, with a temperature rating of -40°F to 200°F (-40°C to 93°C) are available. Low-temperature valves have low-temperature Buna C O-rings. All other materials and ratings are the same as those of standard valves. To order a valve for low-temperature service, add the suffix L to the end of the part number. Example: SS-B3-S4-P-L.

### B3 Series Pressure - temperature Ratings

Material	316 SS		Alloy 400	
Seat Material	PCTFE PEEK	PTFE	PCTFE PEEK	PTFE
Temperature, °F(°C)	Working Pressure, psig (bar)			
-40 to 100 (-40 to 37)	6000 (414)	1500 (103)	5000 (345)	1500 (103)
100 to 200 (37 to 93)	See Pressure vs. Temperature			

### B3H Series Pressure - temperature Ratings

Material	316 SS				
End Connection	F2, F4 S4, SM6	SM10	S6 SM8	S8	SM12
Temperature, °F(°C)	Working Pressure, psig (bar)				
-40 to 100 (-40 to 37)	10000 (690)	8400 (578)	7500 (516)	6700 (461)	6600 (454)
100 to 200 (37 to 93)	See Pressure vs. Temperature				

## Ordering Information

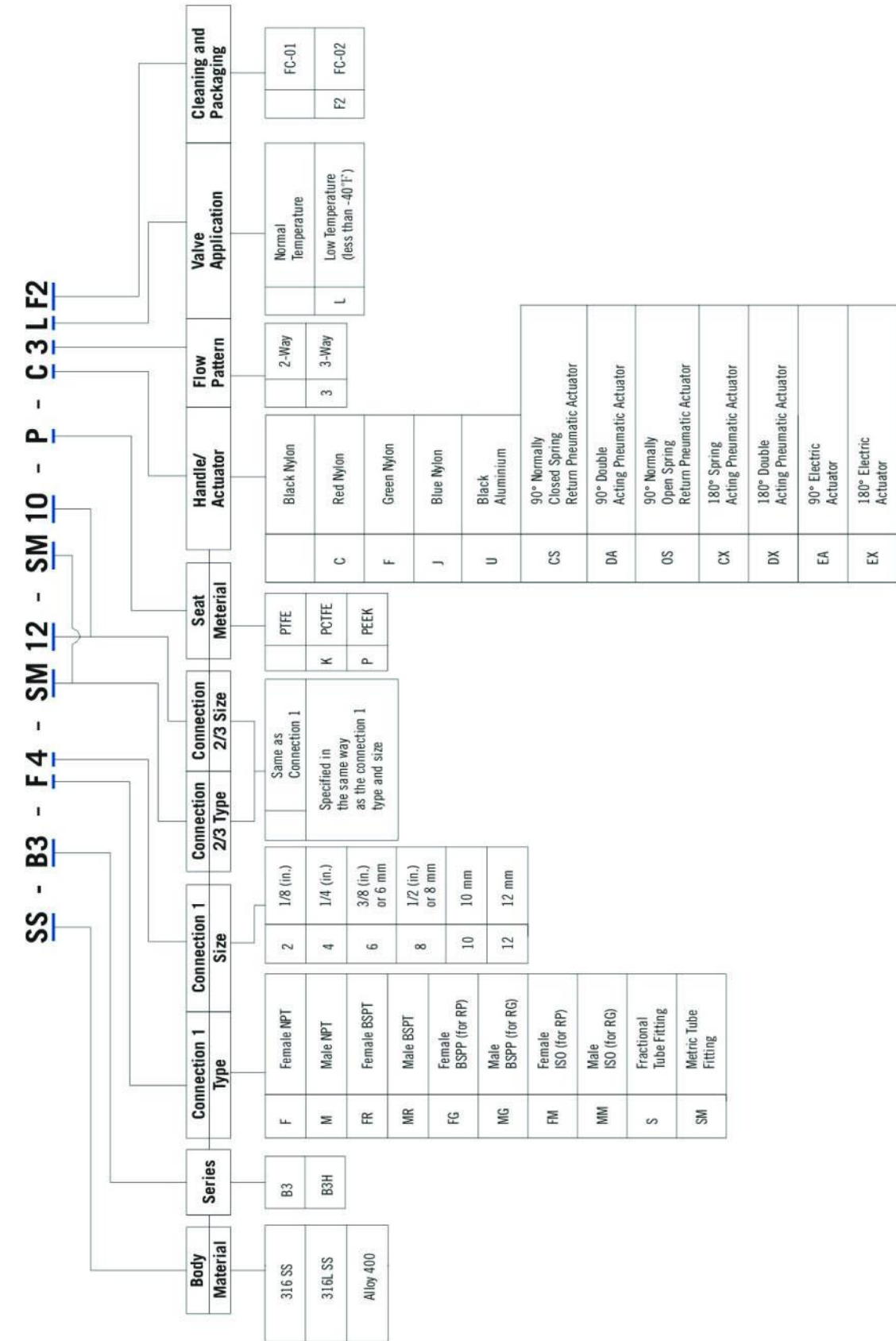

# Bar Stock Ball Valves

## Features

- Working pressure up to 10 000 psig (689 bar)
- Temperature Rating: -50 to 450°F (-46 to 232°C)
- Size from 1/8 in. to 1 in. or 6 mm to 25 mm
- Free floating ball design provides seat wear compensation
- Bi-directional flow for 2-way valves
- Blow out resistant stem with self-sealing function
- 100% factory tested



## Pressure vs. Temperature

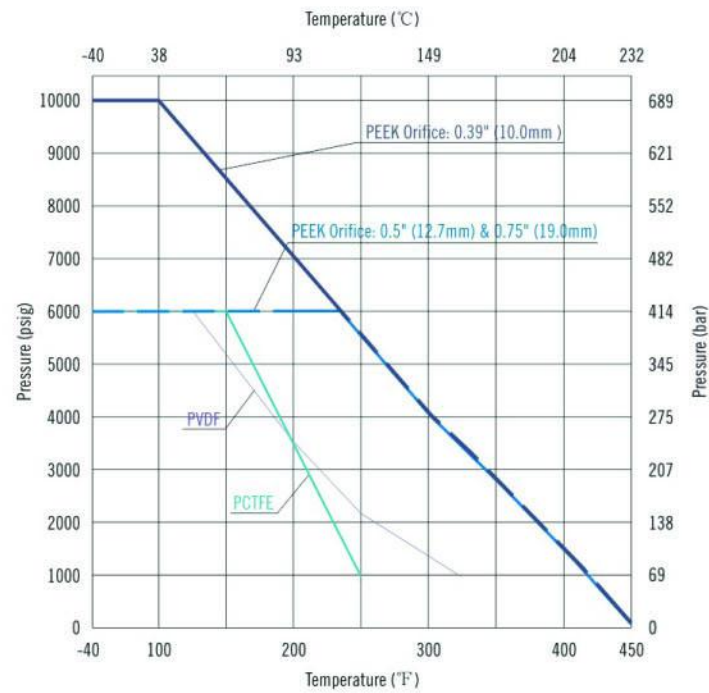

1. Graphs are for 2-way valves only.
2. Maximum working pressure for 3-way valves:  
6000 psig: connection 1 as inlet, connection 2 and connection 3 as outlet  
3000 psig: connection 2 and connection 3 as inlet, connection 1 as outlet

# Bar Stock Ball Valves

## Materials of Construction

### 2-way Valves

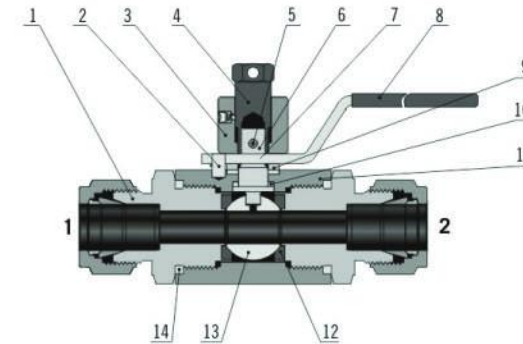

### 3-way Valves

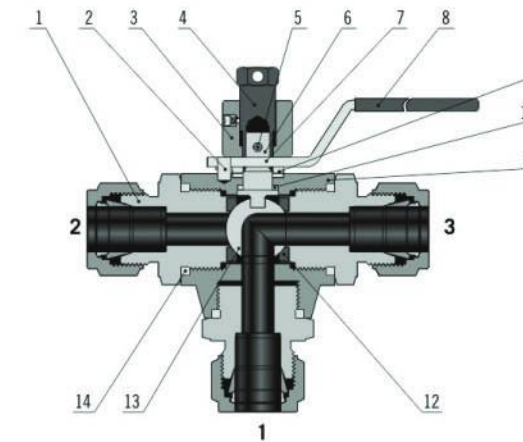

Item	Component	Body Materials		
		316 SS	321 SS	304 SS
1	End connectors	316 SS	321 SS	304 SS
2	Stop pin	Stainless steel		
3	Position lock	316 SS/A276		
4	Gland	316 SS/A276		
5	Set screw	Stainless steel		
6	Stem	316 SS/A276		
7	Handle	Stainless steel		
8	Handle sleeve	vinyl		
9	Stem washer	316 SS/A276		
10	Stem packings	PTFE		
11	Body	316 SS	321 SS	304 SS
12	Seats	PTFE/PCTFE/PEEK		
13	Ball	316 SS/A479		
14	End seals	PTFE/Fluorocarbon FKM/Buna-N		

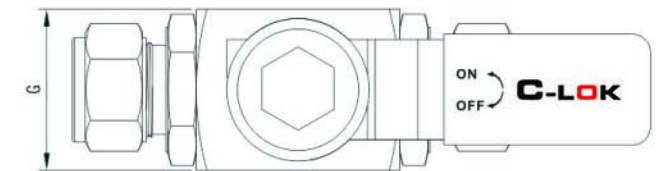

### 2-way Valves

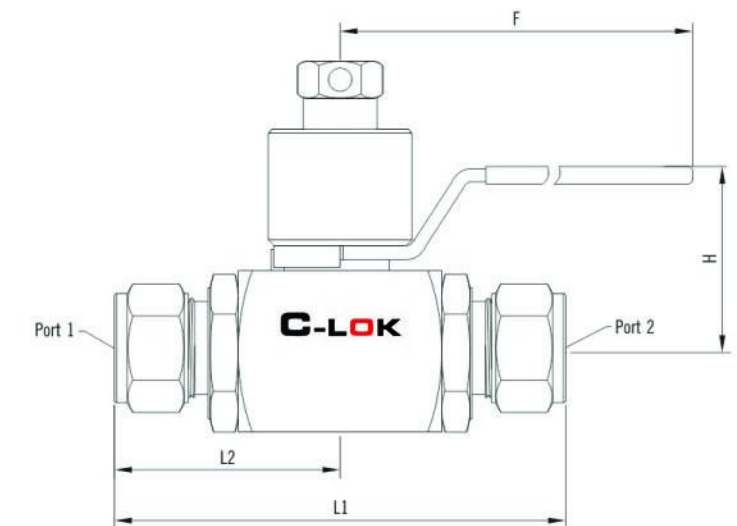

Dimensions

Basic Model Number	End Connection		Orifice in. (mm)	Cv	Dimensions, in. (mm)								
	Port 1	Port 2			L1	L2	F	H	G				
-B4-SM6-10	6mm	6mm	0.39 (10.0)	1.20	3.54 (90.0)	1.77 (45.0)	5.12 (130.0)	1.73 (44.0)	1.30 (32.0)				
-B4-SM8-10	8mm	8mm		3.70	3.60 (91.6)	1.80 (45.8)							
-B4-SM10-10	10mm	10mm		7.50	3.70 (94.0)	1.85 (47.0)							
-B4-SM12-10	12mm	12mm		1.20	3.94 (100.0)	1.97 (50.0)							
-B4-SM14-10	14mm	14mm		3.70	3.60 (91.6)	1.80 (45.8)							
-B4-S4-10	1/4" OD	1/4" OD		7.50	3.72 (94.6)	1.86 (47.3)							
-B4-S6-10	3/8" OD	3/8" OD		3.92 (99.6)	1.96 (49.8)								
-B4-S8-10	1/2" OD	1/2" OD		2.52 (64.0)	1.26 (32.0)								
-B4-F4-10	1/4 Female NPT	1/4 Female NPT		2.80 (71.0)	1.40 (35.5)								
-B4-F6-10	3/8 Female NPT	3/8 Female NPT		3.11 (79.0)	1.56 (39.5)								
-B4-F8-10	1/2 Female NPT	1/2 Female NPT		3.70	3.36 (85.4)	1.68 (42.7)							
-B4-M4-10	1/4 Male NPT	1/4 Male NPT		7.50	3.75 (95.2)	1.88 (47.6)							
-B4-M6-10	3/8 Male NPT	3/8 Male NPT	0.5 (12.7)	10.0	4.04 (102.6)	2.02 (51.3)	5.71 (145.0)	1.89 (48.0)	1.50 (38.0)				
-B4-M8-10	1/2 Male NPT	1/2 Male NPT		4.12 (104.6)	2.06 (52.3)								
-B4-SM16-13	16mm	16mm		4.43 (112.6)	2.22 (56.3)								
-B4-SM18-13	18mm	18mm		4.36 (110.6)	2.18 (55.3)								
-B4-SM20-13	20mm	20mm		3.54 (90.0)	1.77 (45.0)								
-B4-SM22-13	22mm	22mm		4.14 (105.2)	2.07 (52.6)								
-B4-S10-13	5/8" OD	5/8" OD		0.71 (18.0)	19.0	4.87 (123.8)				2.43 (61.9)	6.30 (160.0)	2.08 (53.0)	1.96 (50.0)
-B4-S12-13	3/4" OD	3/4" OD			30.0	5.11 (129.8)				2.66 (64.9)			
-B4-F8-13	1/2 Female NPT	1/2 Female NPT			19.0	4.59 (116.6)				2.29 (58.3)			
-B4-F12-13	3/4 Female NPT	3/4 Female NPT			30.0	5.11 (129.8)				2.66 (64.9)			
-B4-M12-13	3/4 Male NPT	3/4 Male NPT			30.0	3.54 (90.0)				1.77 (45.0)			
-B4-SM20-19	20mm	20mm			30.0	4.26 (108.2)				2.13 (54.1)			
-B4-SM22-19	22mm	22mm	19.0		4.54 (115.2)	2.27 (57.6)							
-B4-SM25-19	25mm	25mm	30.0		4.91 (124.8)	2.45 (62.4)							
-B4-S12-19	3/4" OD	3/4" OD											
-B4-S16-19	1" OD	1" OD											
-B4-F12-19	3/4 Female NPT	3/4 Female NPT											
-B4-F16-19	1 Female NPT	1 Female NPT											
-B4-M12-19	3/4 Male NPT	3/4 Male NPT											
-B4-M16-19	1 Male NPT	1 Male NPT											

3-way Valves



Isolation

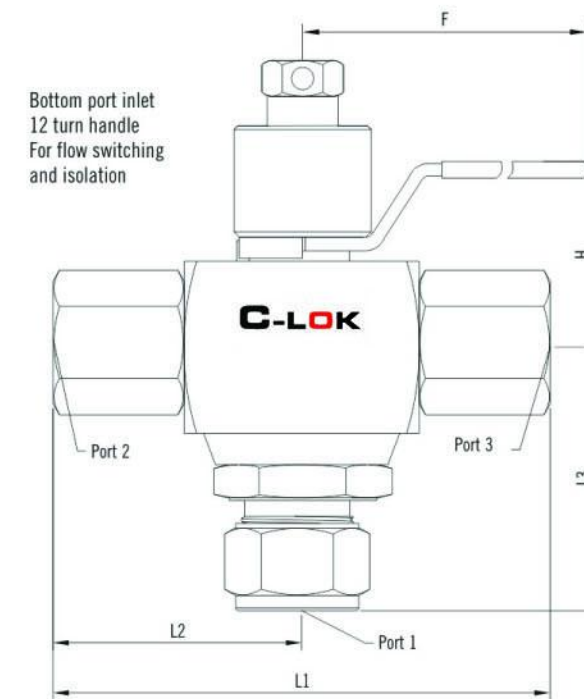

Vertical Pattern

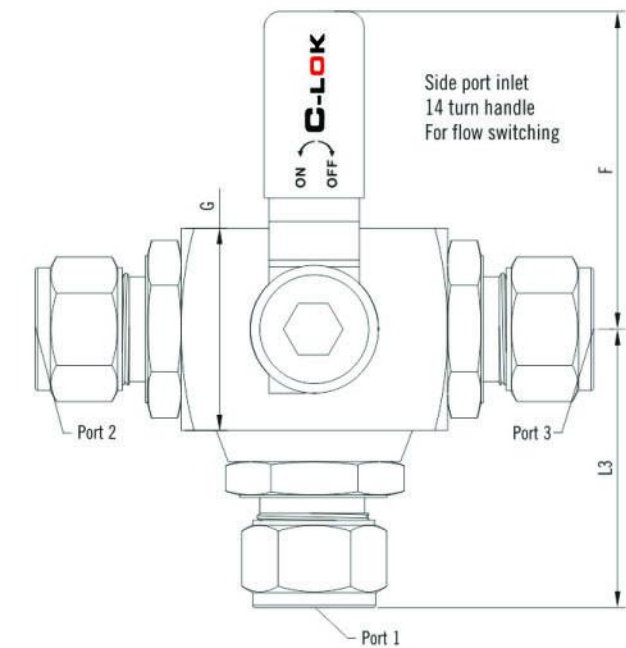

Horizontal Pattern

Dimensions

Basic Model Number	End Connection		Orifice in. (mm)	Cv	Dimensions, in. (mm)										
	Port 1	Port 2/3			L1	L2	L3	F	H	G					
-B4-SM6-10-3	6mm	6mm	0.39 (10.0)	1.20	3.54 (90.0)	1.77 (45.0)	2.00 (50.8)	5.12 (130.0)	1.73 (44.0)	1.30 (32.0)					
-B4-SM8-10-3	8mm	8mm		3.70	3.60 (91.6)	1.80 (45.8)	2.02 (51.3)								
-B4-SM10-10-3	10mm	10mm		7.50	3.70 (94.0)	1.85 (47.0)	2.07 (52.5)								
-B4-SM12-10-3	12mm	12mm		7.50	3.94 (100.0)	1.97 (50.0)	2.18 (55.5)								
-B4-SM14-10-3	14mm	14mm		7.50	3.94 (100.0)	1.97 (50.0)	2.18 (55.5)								
-B4-S4-10-3	1/4" OD	1/4" OD		1.20	3.60 (91.6)	1.80 (45.8)	2.02 (51.3)								
-B4-S6-10-3	3/8" OD	3/8" OD		3.70	3.72 (94.6)	1.86 (47.3)	2.09 (53.1)								
-B4-S8-10-3	1/2" OD	1/2" OD		7.50	3.92 (99.6)	1.96 (49.8)	2.13 (54.0)								
-B4-F4-10-3	1/4 Female NPT	1/4 Female NPT			2.52 (64.0)	1.26 (32.0)	1.44 (36.5)								
-B4-F6-10-3	3/8 Female NPT	3/8 Female NPT			2.80 (71.0)	1.40 (35.5)	1.57 (40.0)								
-B4-F8-10-3	1/2 Female NPT	1/2 Female NPT		3.70	3.11 (79.0)	1.56 (39.5)	1.73 (44.0)								
-B4-M4-10-3	1/4 Male NPT	1/4 Male NPT		7.50	3.36 (85.4)	1.68 (42.7)	1.90 (48.2)								
-B4-M6-10-3	3/8 Male NPT	3/8 Male NPT	3.75 (95.2)		1.88 (47.6)	2.09 (53.1)									
-B4-M8-10-3	1/2 Male NPT	1/2 Male NPT	3.75 (95.2)		1.88 (47.6)	2.09 (53.1)									
-B4-SM16-13-3	16mm	16mm	0.5 (12.7)	10.0	4.04 (102.6)	2.02 (51.3)	2.41 (61.3)	5.71 (145.0)	1.89 (48.0)	1.50 (38.0)					
-B4-SM18-13-3	18mm	18mm			4.12 (104.6)	2.06 (52.3)	2.45 (62.3)								
-B4-SM20-13-3	20mm	20mm			4.43 (112.6)	2.22 (56.3)	2.61 (66.3)								
-B4-SM22-13-3	22mm	22mm			4.36 (110.6)	2.18 (55.3)	2.57 (65.3)								
-B4-S10-13-3	5/8" OD	5/8" OD			3.54 (90.0)	1.77 (45.0)	1.95 (49.5)								
-B4-S12-13-3	3/4" OD	3/4" OD					2.16 (55.0)								
-B4-F8-13-3	1/2 Female NPT	1/2 Female NPT					4.14 (105.2)				2.07 (52.6)	2.46 (62.6)			
-B4-F12-13-3	3/4 Female NPT	3/4 Female NPT			19.0	30.0	4.87 (123.8)				2.43 (61.9)	2.89 (73.4)	6.30 (160.0)	2.08 (53.0)	1.96 (50.0)
-B4-M12-13-3	3/4 Male NPT	3/4 Male NPT					4.43 (112.6)				2.22 (56.3)	2.61 (66.3)			
-B4-SM20-19-3	20mm	20mm					5.11 (129.8)				2.66 (64.9)	3.00 (76.2)			
-B4-SM22-19-3	22mm	22mm			19.0	4.59 (116.6)	2.29 (58.3)				2.75 (69.8)				
-B4-SM25-19-3	25mm	25mm			30.0	5.11 (129.8)	2.66 (64.9)				3.00 (76.2)				
-B4-S12-19-3	3/4" OD	3/4" OD	3.54 (90.0)	1.77 (45.0)				2.22 (56.5)							
-B4-S16-19-3	1" OD	1" OD	4.26 (108.2)	2.13 (54.1)				2.40 (60.8)							
-B4-F12-19-3	3/4 Female NPT	3/4 Female NPT	19.0	4.54 (115.2)	2.27 (57.6)	2.72 (69.1)									
-B4-F16-19-3	1 Female NPT	1 Female NPT					4.91 (124.8)	2.45 (62.4)	2.90 (73.9)						
-B4-M12-19-3	3/4 Male NPT	3/4 Male NPT					30.0	4.91 (124.8)	2.45 (62.4)	2.90 (73.9)					
-B4-M16-19-3	1 Male NPT	1 Male NPT													

Ordering Information

SS - B4 - SM 20 - S 12 - F 8 - P 13 - V - U 3

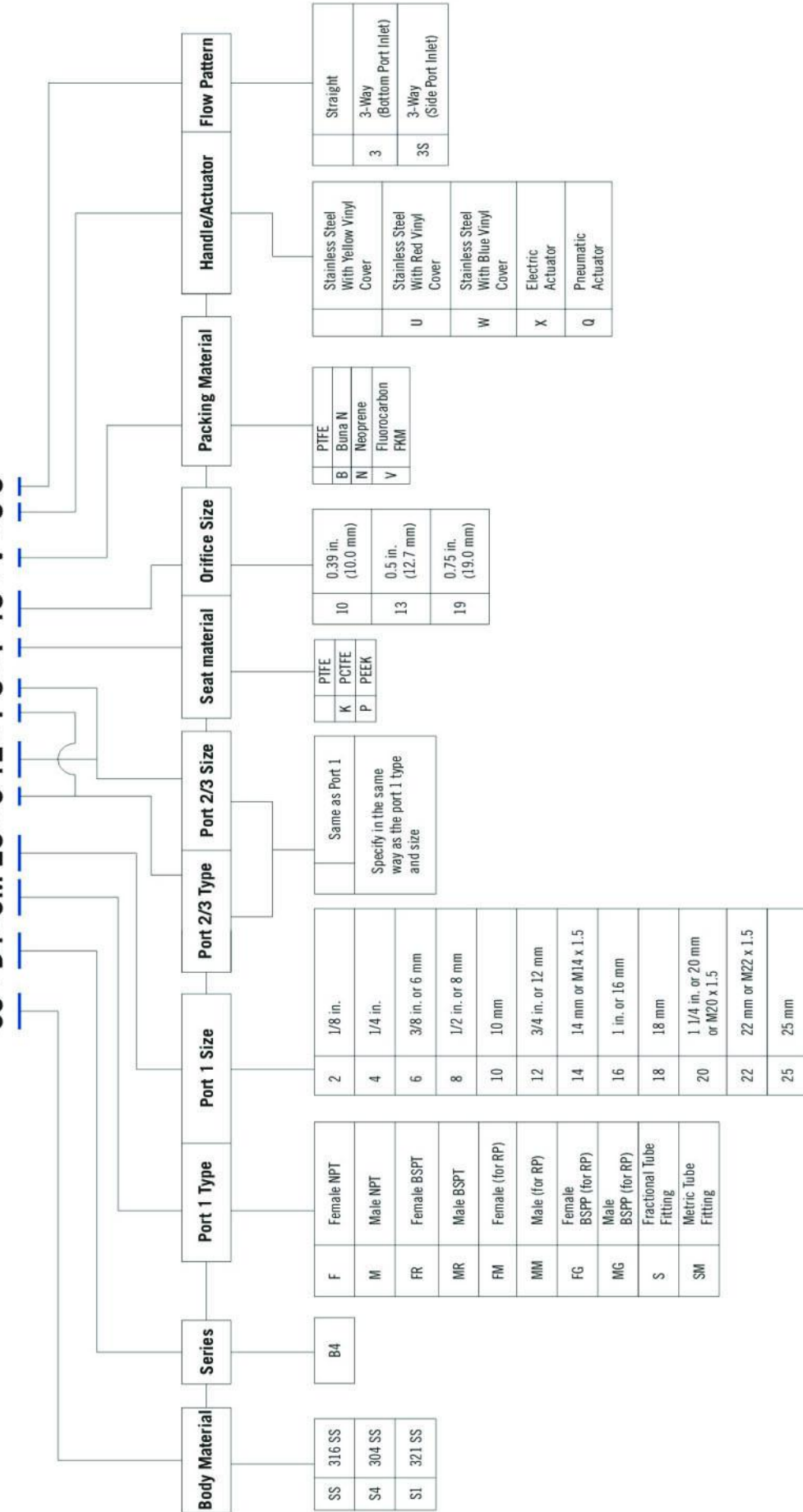

# 3-piece Ball Valves

## Features

### B5 Series

- Maximum working pressure: 3000 psig (207 bar)
- Working temperature: -20°F to 450°F (-28°C to 232°C)
- End connections:
  - 1/8 to 2 thread
  - 1/8 to 2 pipe butt or socket weld
  - 1/2" to 2" and 12 mm to 50 mm tube butt or socket weld
  - 1/2" to 2" and 12 mm to 38 mm tube fitting
  - 1/2 to 4 flange
- Orifice sizes: 4.8 mm to 50 mm
- Compensating seat design
- Live-loaded V-type stem packing pack for constant sealing
- Blowout proof stem
- Fire-safe design available
- Continuous anti-static protection
- Pneumatic and electric actuation available
- Panel mountable
- Options for handle color
- Pneumatic and electric actuation available
- Leak-tight performance testing for every valve at the maximum working pressure with nitrogen



## Pressure vs. Temperature

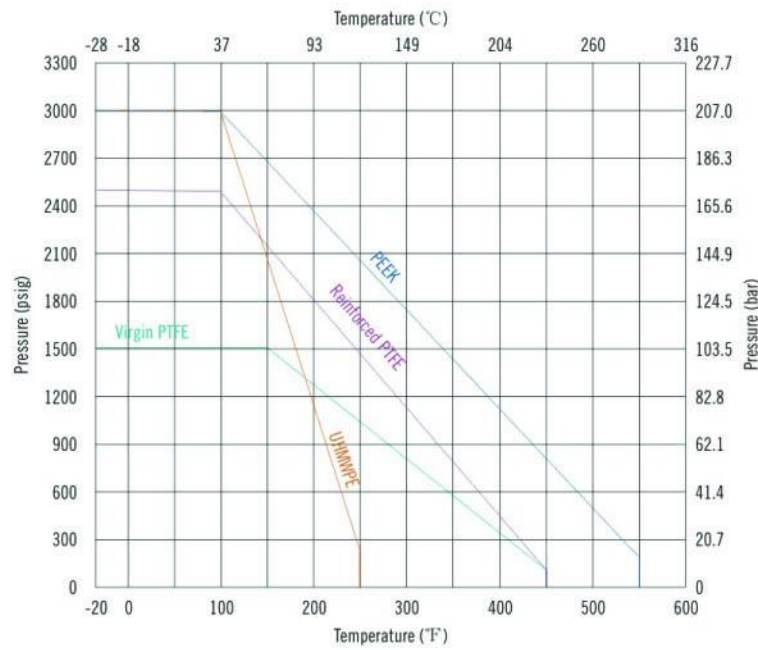

# 3-piece Ball Valves

## Standard Materials of Construction

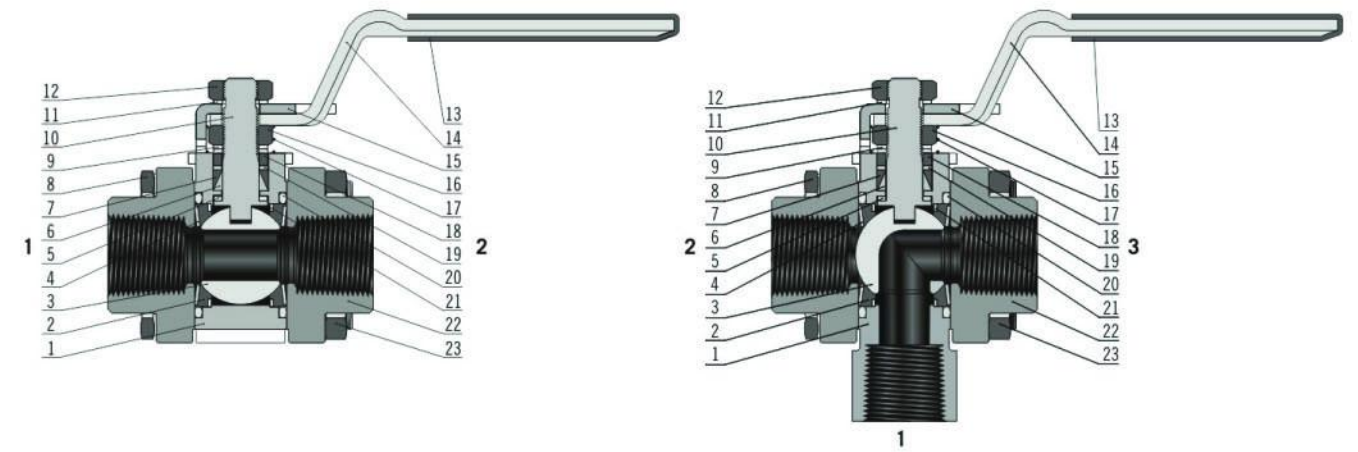

Item	Component	Valve Body Material			
		Material Grade/ASME Specification			
1	Body	CF8M/A351	CF3M/A351	CF8/A351	CF3/A351
2	Seat	PTFE/D1710			
3	Ball	316 SS/A276			
4	Coned-disc Spring	Strain-hardened 316 SS/A240			
5	Stem Bearing	PEEK (Polyetheretherketone)			
6	Lower Packing	Reinforced PTFE			
7	Upper Packing	Reinforced PTFE			
8	Body Bolt	Gr. B8M/A193			
9	Stem Spring	Strain-hardened 316 SS/A240			
10	Stem	316 SS/A479			
11	Stem Spring	Strain-hardened 316 SS/A240			
12	Stem Nut	Gr. 8M/A194			
13	Handle Sleeve	Viny			
14	Handle	304 SS/A240			
15	Stop Plate	304 SS/A240			
16	Stem Nut	Gr. 8M/A194			
17	Grounding Spring	302 SS/A313			
18	Gland	PTFE-coated 316 SS/B783			
19	Packing Support	PEEK (Polyetheretherketone)			
20	Flange Seal	Fluorocarbon FKM			
21	Support Ring	316 SS/A240			
22	Flange	CF8M/A351	CF3M/A351	CF8/A351	CF3/A351
23	Body Nut	Gr.8M/A194			
	Lubricants	Silicone-based and PTFE-based			

Other materials available upon request.

# 3-piece Ball Valves

## Fire-safe Application

### Features

- Maximum working pressure: 2200psig (152bar)
- Working temperature: -20°F to 400°F (-28°C to 244°C)
- Live-loaded Graphite stem packing
- High strength metal stem bearing
- Encased 8-bolt construction
- Graphite flange seals and seat seals
- Fire-safe valves are designed, tested to meet the requirement of API 607 4th edition

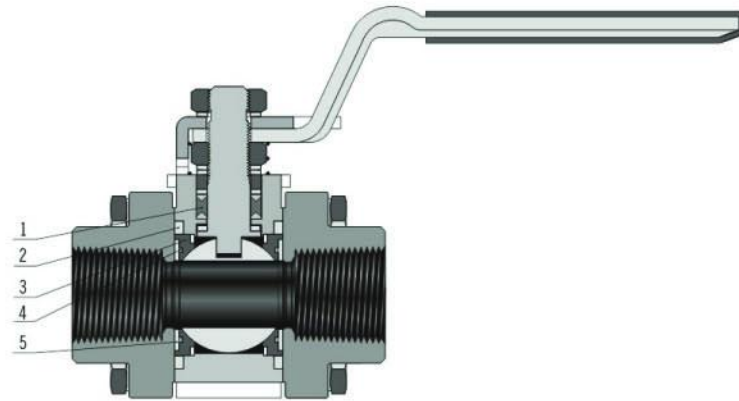

## Standard Materials of Construction

Item	Component	Valve Body Material			
		CF8M/A351	CF3M/A351	CF8/A351	CF3/A351
1	Packing	Graphite			
2	Flange Seal	Graphite with 316 SS wire			
3	Seat	Reinforced PTFE			
4	Seat Ring	Graphite with 316 SS wire			
5	Coned-disc spring	Grafoil-lined 316 SS/A167			

All other components are same as general application.

## Pressure vs. Temperature

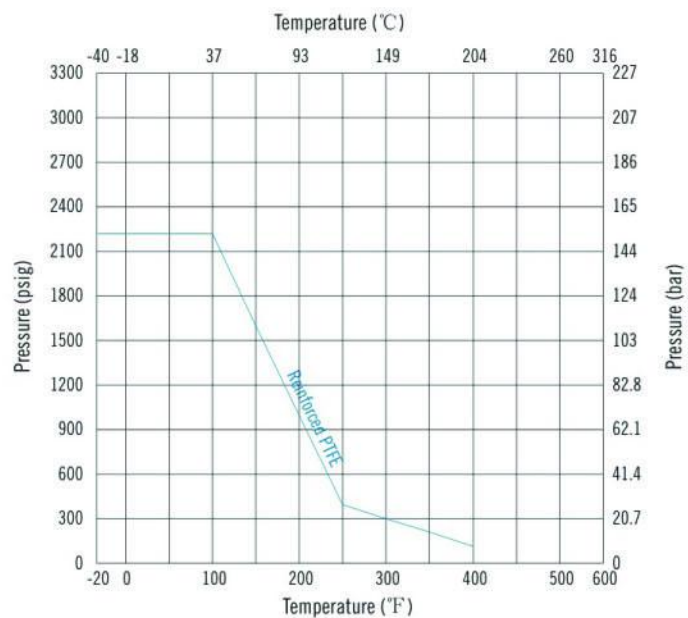

# 3-piece Ball Valves

## Steam Service

### Features

- Maximum working pressure: 2500psig (172bar)
- Working temperature: -20°F to 600°F (-28°C to 316°C)
- Encased 8-bolt construction
- Graphite flange seals
- PEEK seats and stem seals

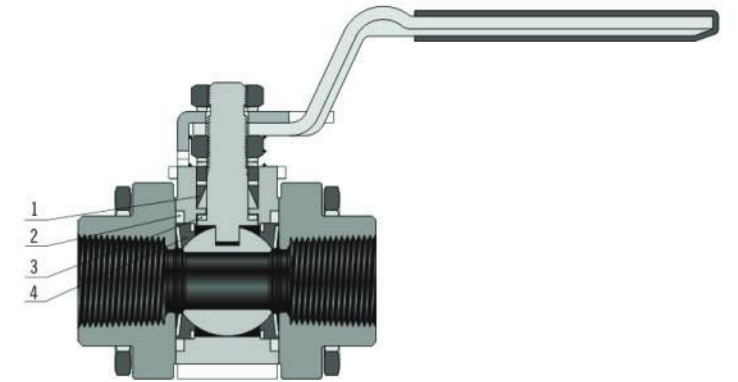

## Materials of Construction

Item	Component	Valve Body Material			
		CF8M/A351	CF3M/A351	CF8/A351	CF3/A351
1	Packing	Molybdenum disulfide-coated PEEK			
2	Flange Seal	Graphite with 316 SS			
3	Stem bearing	Molybdenum disulfide-coated PEEK			
4	Seat	Molybdenum disulfide-coated PEEK			
	Lubricant	PTFE-based			

All other components are same as general application.

## Pressure vs. Temperature

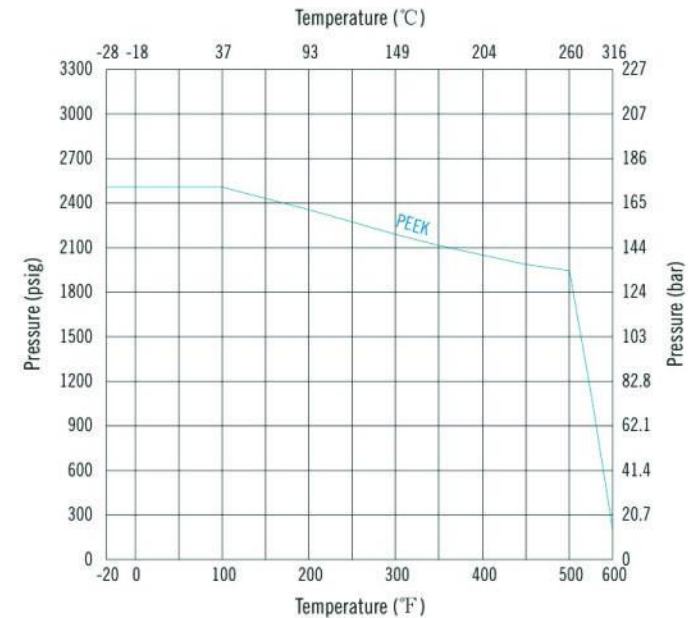

## Thermal Service

### Features

- Maximum working pressure: 1000psig (68.9bar)
- Working temperature: -65°F to 850°F (-54°C to 454°C)
- Spring-loaded metal seats
- Encased 8-bolt Construction

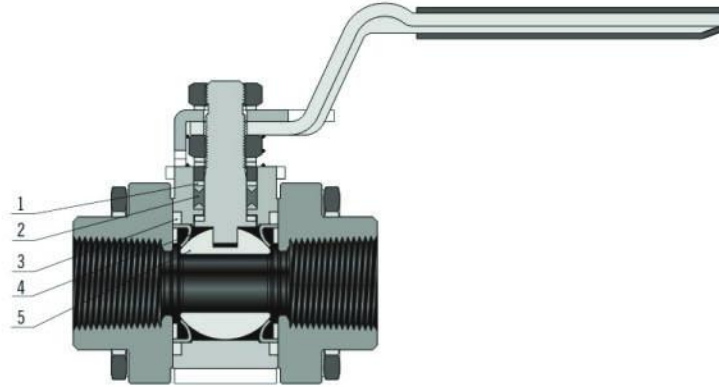

## Materials of Construction

Item	Component	Valve Body Material			
		CF8M/A351	CF3M/A351	CF8/A351	CF3/A351
1	Packing bearing	Alloy X-750 /AMS 5542			
2	Packing	Graphite with 316 SS			
3	Flange seal	Graphite with 316 SS			
4	Seat	Alloy X-750 /AMS 5542			
5	Ball	S17400 SS/A564			
Lubricant		Fluorinated tungsten disulfide			

All other components same as general application.

## Pressure vs. Temperature

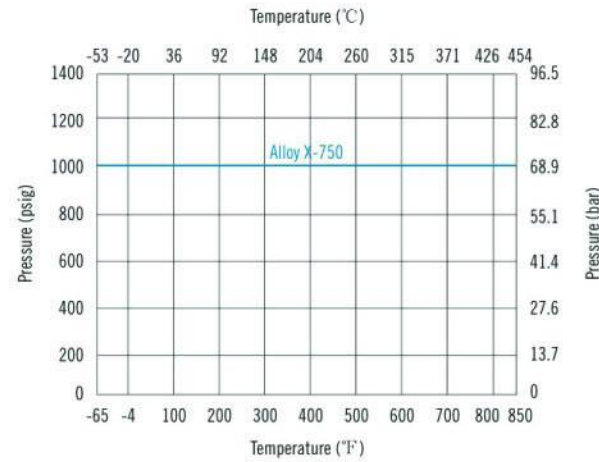

## Dimensions

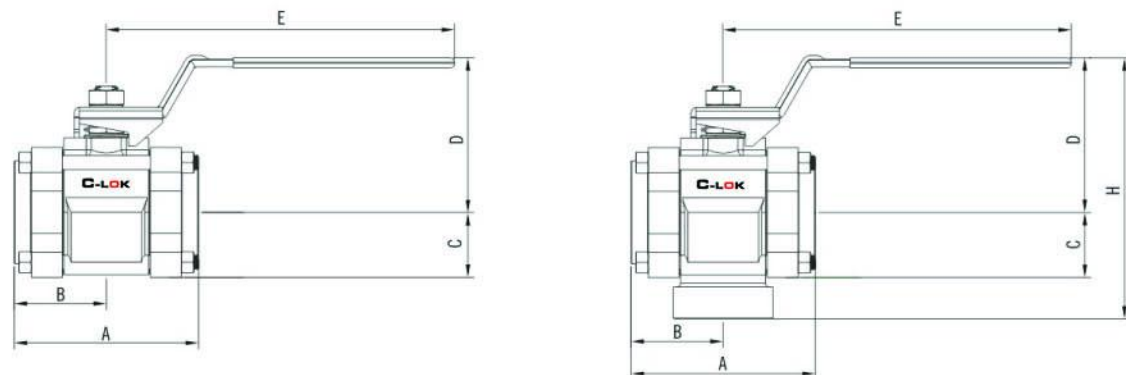

## Dimensions

Basic Ordering Number	Connection Type and Size		Orifice in. (mm)	Cv	Dimension, in. (mm)					
	Connection 1	Connection 2/3			A	B	C	D	E	H
-B5-S4-05	1/4" OD	1/4" OD	0.188 (4.8)	1.2	3.17 (80.5)	1.59 (40.4)	0.68 (17.3)	2.37 (60.2)	1.66 (42.2)	3.35 (85.1)
-B5-SM6-05	6 mm	6 mm								
-B5-SM8-05	8 mm	8 mm								
-B5-SW4-05	1/4" SW	1/4" SW								
-B5-MS6-05	3/8" MS	3/8" MS								
-B5-PB4-05	1/4 PB	1/4 PB								
-B5-F2-07	1/8 Female NPT	1/8 Female NPT	0.281 (7.1)	3.8	2.16 (54.9)	1.08 (27.4)	0.68 (17.3)	1.66 (41.2)	2.37 (60.2)	3.12 (79.2)
-B5-FR2-07	1/8 Female BSPT	1/8 Female BSPT								
-B5-FG2-07	1/8 Female BSPP	1/8 Female BSPP								
-B5-F4-07	1/4 Female NPT	1/4 Female NPT								
-B5-FR4-07	1/4 Female BSPT	1/4 Female BSPT								
-B5-FG4-07	1/4 Female BSPP	1/4 Female BSPP								
-B5-S5-07	5/16" OD	5/16" OD								
-B5-S6-07	3/8" OD	3/8" OD								
-B5-SM10-07	10 mm	10 mm								
-B5-SW6-07	3/8" SW	3/8" SW								
-B5-PB6-07	3/8 PB	3/8 PB								
-B5-S8-10	1/2" OD	1/2" OD	0.406 (10.3)	7.5	4.04 (102.6)	2.02 (51.3)	0.89 (22.6)	2.35 (59.7)	4.50 (114.0)	4.48 (114)
-B5-SM12-10	12 mm	12 mm	0.375 (9.5)							
-B5-SW8-10	1/2" SW	1/2" SW	0.411 (10.4)							
-B5-F6-13	3/8 Female NPT	3/8 Female NPT	0.516 (13.1)	12	2.70 (68.6)	1.35 (34.3)	0.89 (22.6)	2.35 (59.7)	4.50 (114.0)	4.19 (106)
-B5-FR6-13	3/8 Female BSPT	3/8 Female BSPT								
-B5-FG6-13	3/8 Female BSPP	3/8 Female BSPP								
-B5-F8-13	1/2 Female NPT	1/2 Female NPT								
-B5-FR8-13	1/2 Female BSPT	1/2 Female BSPT								
-B5-FG8-13	1/2 Female BSPP	1/2 Female BSPP								
-B5-S12-13	3/4" OD	3/4" OD								
-B5-SM16-13	16 mm	16 mm								
-B5-SM18-13	18 mm	18 mm								
-B5-SW12-13	3/4" SW	3/4" SW								
-B5-PS8-13	1/2 PS	1/2 PS								
-B5-PB8-13	1/2 PB	1/2 PB								
				13.6	4.04 (102.6)	2.02 (51.3)				4.84 (123)
				15	2.70 (68.6)	1.34 (34.0)				
					2.69 (68.3)	1.34 (34.0)				



Dimensions

Basic Ordering Number	Connection Type and Size		Orifice in. (mm)	Cv	Dimension, in. (mm)					
	Connection 1	Connection 2/3			A	B	C	D	E	H
-B5-PB12-13	3/4 PB	3/4 PB	0.516 (13.1)	13.6	2.69 (68.3)	1.34 (34)	0.89 (22.6)	2.35 (59.7)	4.5 (114)	
-B5-F12-22	3/4 Female NPT	3/4 Female NPT	0.875 (22.2)	31	3.59 (91.2)	1.8 (45.7)	1.25 (31.8)	2.94 (74.7)	6 (152)	5.45 (138)
-B5-FR12-22	3/4 Female BSPT	3/4 Female BSPT								
-B5-FG12-22	3/4 Female BSPP	3/4 Female BSPP								
-B5-F16-22	1 Female NPT	1 Female NPT								
-B5-FR16-22	1 Female BSPT	1 Female BSPT								
-B5-FG16-22	1 Female BSPP	1 Female BSPP								
-B5-S16-22	1" OD	1" OD		40	5.36 (136)	2.68 (68)	1.25 (31.8)	2.94 (74.7)	6 (152)	
-B5-S20-22	1 1/4" OD	1 1/4" OD								
-B5-SM25-22	25 mm	25 mm		40	5.36 (136)	2.68 (68)	1.25 (31.8)	2.94 (74.7)	6 (152)	
-B5-SM28-22	28 mm	28 mm								
-B5-SW16-22	1" SW	1" SW		38	3.59 (91.2)	1.8 (45.7)	1.25 (31.8)	2.94 (74.7)	6 (152)	
-B5-MS25-22	25 mm MS	25 mm MS								
-B5-PS12-22	3/4 PS	3/4 PS		36	3.59 (91.2)	1.8 (45.7)	1.25 (31.8)	2.94 (74.7)	6 (152)	
-B5-PS16-22	1 PS	1 PS								
-B5-PB12-22	3/4 PB	3/4 PB		36	3.46 (87.9)	1.73 (43.9)	1.25 (31.8)	2.94 (74.7)	6 (152)	
-B5-PB16-22	1 PB	1 PB								
-B5-SW20-29	1 1/4" SW	1 1/4" SW	80	4.39 (112)	2.19 (55.6)	1.53 (38.9)	4.03 (102)	9.14 (232)		
-B5-PB20-29	1 1/4 PB	1 1/4 PB								
-B5-F20-32	1 1/4 Female NPT	1 1/4 Female NPT	100	4.39 (112)	2.19 (55.6)	1.53 (38.9)	4.03 (102)	9.14 (232)		
-B5-F24-32	1 1/2 Female NPT	1 1/2 Female NPT								
-B5-SW24-32	1 1/2" SW	1 1/2" SW								
-B5-PS20-32	1 1/4 PS	1 1/4 PS								
-B5-PS24-32	1 1/2 PS	1 1/2 PS	100	4.57 (116)	2.28 (57.9)	1.53 (38.9)	4.03 (102)	9.14 (232)		
-B5-PB24-32	1 1/2 PB	1 1/2 PB								
-B5-F32-38	2 Female NPT	2 Female NPT	130	4.94 (125.4)	2.47 (62.7)	1.74 (44.2)	4.16 (106)	9.14 (232)		
-B5-FR32-38	2 Female BSPT	2 Female BSPT								
-B5-SW32-38	2" SW	2" SW								
-B5-PS32-38	2 PS	2 PS								
-B5-PB32-38	2 PB	2 PB								

1. SW means fractional tube socket weld, MS means metric tube socket weld, BW means fractional tube butt weld, MB means metric tube butt weld, PS means pipe socket weld, PB means pipe butt weld.  
 2. Sizes and types listed are standard. Other sizes and types are available upon request, refer to the ordering information.

Ordering Information

SS - B5 - F 8 - FR 8 - S 8 - P 13 R - OS 3 I F 2

